

## INTRODUCTION

AIM Connectors enable the connection of luer fittings to AIM 3D Cell Culture Chips thus expanding the applications of AIM chips in life sciences research. This protocol covers the basic techniques to handle AIM Connectors, prepare & fill collagen gel, coat media channels, seed cells and change medium. The formation of an endothelial monolayer in the AIM chips is used here as an illustrative example.

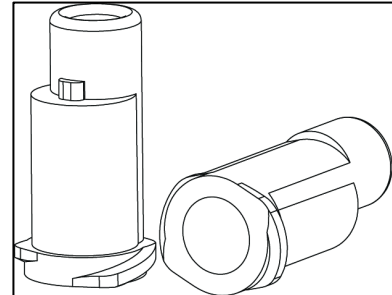

## SCHEMATIC

The following schematic shows the 3D presentation and section view of a Luer Connector. This nomenclature will be used in this protocol.

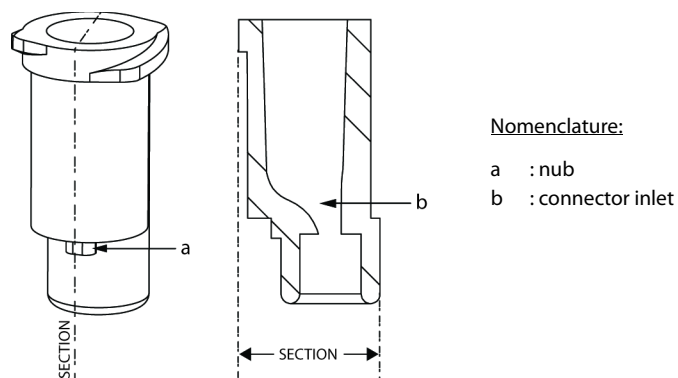

## TABLE OF CONTENTS

INTRODUCTION .....	1
SCHEMATIC .....	1
TABLE OF CONTENTS .....	2
ASSEMBLING CONNECTORS .....	3
PREPARING & FILLING COLLAGEN GEL .....	4
HYDRATING & COATING MEDIA CHANNELS .....	6
SEEDING CELLS .....	7
CHANGING MEDIUM .....	8

## ASSEMBLING CONNECTORS **TIMING** 10 min

### MATERIALS

#### Others

- AIM Connectors
- AIM 3D Cell Culture Chips

1. Fit the connectors into all four media inlets by aligning the nub of the connectors to the corresponding indent at the ports.

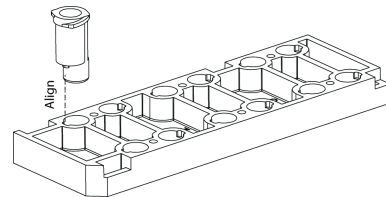

**! Critical** To avoid the generation of bubbles, connectors have to be fitted into AIM chips before the media channels are hydrated with culture medium/coating solution. We recommend fitting them into the empty AIM chips before hydrogel is filled for easier handling experience.

2. Press the connectors down into the AIM chips to make sure the contact areas between the connectors and the AIM chips are flush to prevent any leakage of fluid.

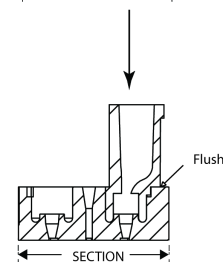
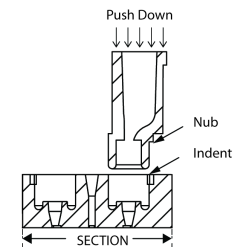
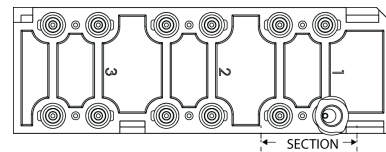

## PREPARING & FILLING COLLAGEN GEL ⌚ TIMING 50 min

### MATERIALS

#### Reagents

- 10 X PBS with phenol red (see REAGENT SETUP in the General Protocol; Life Technologies, Cat. No. 70011044)
- Sodium hydroxide solution, 0.5 M (see REAGENT SETUP in the General Protocol; Sigma-Aldrich, Cat. No. 221465)
- Sterile deionized water (Thermo Water Purifying System)
- Collagen type I, rat tail (Corning Life Science, Cat. No. 354236)
- Cell culture medium (Lonza, Cat. No. CC3202)

#### Others

- **AIM Inlet Seals**
- AIM chips
- AIM holders or humidified chambers
- 1.5 ml microcentrifuge tube
- Pocket size pH meter (Hach, Cat. No. H138) or pH papers (Sigma Aldrich, Cat. No. 37144)
- Ice bucket or styrofoam box
- Ice

3. Keep 10X PBS with phenol red, collagen stock solution, 0.5 M NaOH solution and deionized water on ice and add them into a microcentrifuge tube (on ice) sequentially according to the pre-determined collagen gel recipe.
4. Mix the solution thoroughly by using a micropipette to get a collagen solution with homogeneous faint pink color.
5. Assemble AIM chips into an AIM holder (see Instructions For Use for the AIM holder included in the package).
6. Draw 10  $\mu$ L of collagen solution with a 1- 10  $\mu$ L micropipette. Make sure the collagen solution is kept on ice at all times.
7. Fill the chip from either gel inlet:
  - a. **Option 1:** Fill collagen solution from either one of the inlets and stop near the end of posts. Fill from the other inlet until the gel fronts merge. This method is recommended for new users.

**! Critical** Limit the volume of collagen solution to 10  $\mu$ l to prevent the collagen solution from overflowing into media channels.

**! Critical**, Hold the plunger firmly while removing the micropipette from the inlets, otherwise the negative pressure will suck the collagen up.

**! Critical** Avoid discharging collagen solution abruptly to prevent the collagen solution from overflowing into media channels.

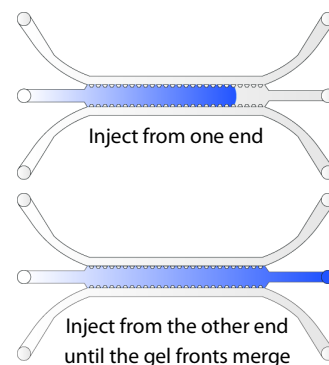

- b. **Option 2:** Fill collagen solution from one side all the way to the other side. Continue to push the collagen solution in gently until it reaches the other inlet. This method ensures that the gel is being filled homogeneously but it requires greater control over pipetting pressure (especially when the collagen solution reaches the opposite inlet) to prevent the collagen solution from overflowing into the flanking media channels.
8. Seal the gel inlets immediately with **AIM Inlet Seals** by using tweezers. This is to prevent leaks from the gel inlets. Fluid will flow from the media ports to the gel inlets if the fluid levels at the media ports are higher than the gel inlets.
9. Add 6 ml of water into the reservoirs of the AIM holder. Alternatively, prepare a humidified chamber to house the chips (e.g. by adding water into a pipette tip box until approximately 1/3 is filled; both water and pipette tip box should be sterile).
10. If humidified chambers are used, pre-warm the humidified chambers to 37 °C by putting them in an incubator.
11. Place the gel-filled chips (on AIM holders or in humidified chambers) into a 37 °C incubator and incubate for half an hour to allow the polymerization of collagen to take place.

**Reminder** Handle the connectors and inlet seals with proper aseptic techniques. Keep the unused connectors and inlet seals in a sealed and sterile bag (as provided).

**Reminder** You may seal the gel inlets after the polymerization of hydrogel. Make sure the areas around the gel inlets are completely dry before sealing them with inlet seals.

**! Critical** AIM chips are laminated with a gas-permeable film that enables gas exchange to take place. The bottom of the chips should therefore be exposed to allow for air circulation.

**Reminder** Pre-warming of AIM holders is not necessary as the AIM holders allow direct contact of AIM chips with warm air when placed in an incubator.

**Reminder** The polymerization time can be optimized to suit your specific application.

**! Critical** Temperature will affect collagen polymerization and 37 °C is recommended for most applications.

**! Critical** Chips with unpolymerized gel must be handled with care. Excessive agitation or impact may cause the unpolymerized gel to leak out of the gel channel.

## HYDRATING & COATING MEDIA CHANNELS **TIMING** 70 min

### MATERIALS

#### Reagents

- Fibronectin (Sigma-Aldrich, Cat. No. F0895) or any coating reagent for your specific application

**! Critical** Collagen coating is not suitable for collagen-filled AIM chips as the solvent of the collagen coating solution may dissolve the polymerized collagen.

#### Others

- Collagen-filled AIM chips (with connectors attached and inlets sealed)

12. After incubation, insert a pipette tip into either connector inlet of the media channel that requires coating and push gently until the tip fits. Inject 15  $\mu$ l of coating solution (e.g. 50  $\mu$ g/ml fibronectin solution diluted in culture medium or 1X PBS) into the channel. Repeat this step for the other channel. Use culture medium to hydrate the media channels if coating is not required.

**! Critical** Hold the plunger firmly while removing the micropipette from the inlets, otherwise the negative pressure will suck the coating solution/medium up.

13. Incubate the media-channel-hydrated chips (on AIM holders or in humidified chambers) for 1 h in a 37°C incubator.

14. Add 100  $\mu$ l of medium into a connector and let it flow into the media channel to flush out the coating solution. Repeat this for the other channels. If the coating solution has to be removed completely, wash the media channels with culture medium by repeating this step twice.

**Reminder** Media channels have to be hydrated with culture medium/coating solution after the polymerization of collagen. This is to prevent the collagen gel in the chips from drying up.

▪ **PAUSE POINT** The media-channel-hydrated chips can be kept in an incubator for not more than 2 days before the seeding steps depending on your application (In a single experiment, do not mix the media-channel-hydrated chips that are prepared at different time points because the properties of collagen may change over time).

## SEEDING CELLS TIMING 40 min

### MATERIALS

#### Reagents

- 1X PBS (Life Technologies, Cat. No. 70011044)
- 0.25% trypsin with EDTA (Lonza, Cat. No. CC5012)
- Cell culture medium (Lonza, Cat. No. CC3202)

#### Others

- Collagen-filled and fibronectin-coated AIM chips (with connectors attached and inlets sealed)
- Cells
- Centrifuge

15. Trypsinize cells as per protocol.
16. Re-suspend the cells in culture medium with densities ranging from 0.5 M to 3 M cells/ml, depending on cell types and applications. For example, endothelial cells at a density of 1.5 M cells/ml are suitable for obtaining a confluent monolayer overnight.
17. Remove medium from all connectors by using a micropipette until the medium levels are the same as or slightly above the connector inlets. Do not apply negative pressure directly at the connector inlets to prevent the medium in the media channels from being removed.

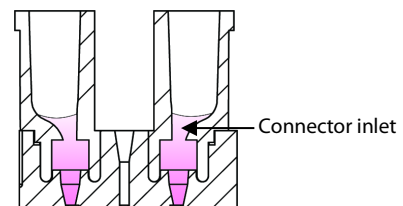

**Reminder** You may use an aspirator to remove medium from the connectors, but you need to handle the aspirator with **EXTRA** care (not to insert the tip of aspirator into the connector inlets). This is to avoid the complete removal of medium from the media channels.

18. Add 20  $\mu$ l of endothelial cell suspension into a connector. Wait for 2 min and then repeat the same procedure for the opposite connector that is attached to the same media channel. In total, 40  $\mu$ l of endothelial cell suspension is seeded per media channel. The additional 40  $\mu$ l of fluid creates a height difference between the two media channels thus generating interstitial flow across the gel that helps the attachment of endothelial cells on the gel interface.
19. Visual inspection under a microscope is recommended. If the cell distribution is not optimal for your application, adjust the concentration of the cell suspension and repeat the seeding steps.
20. If another cell type B is to be seeded in the opposite media channel, incubate the chips for at least 30 min after cell type A has been seeded to allow proper attachment of cell type A on the substrates. Repeat the seeding steps for cell type B.
21. Keep the chips in an incubator and proceed to step 22.

**! Critical** Lay chips (on AIM holders or in humidified chambers) on a flat surface while seeding cells into AIM chips. Inclination of the chips affects the flow in the media channel, thus disturbing cell distribution.

## CHANGING MEDIUM TIMING 10 min

### MATERIALS

#### Reagents

- Cell culture medium (Lonza, Cat. No. CC3202)
- 

22. (Optional) Change medium 2 to 4 h (or longer for less adhesive cell types) after the cells have been seeded.
23. Remove medium from all connectors by using a micropipette. Add 100  $\mu$ l of fresh medium into a connector to flush out the old medium from the opposite connector that is attached to the same media channel. Repeat this for the other channels.
24. Keep the chips in an incubator. Endothelial cells should form a confluent monolayer covering the channel in 1 d. If the cells need to be kept longer in culture, change medium daily as described in step 23. Alternatively, you may proceed to flow applications (please refer to protocol for flow application) by using auxiliary reservoirs or syringe pumps, depending on your application.

**Reminder** You may use an aspirator to remove medium from the connectors, but you need to handle the aspirator with EXTRA care (not to insert the tip of aspirator into the connector inlets). This is to avoid the complete removal of medium from the media channels.

**Reminder** If slower flow speed in the media channel is required, you may either reduce the volume of medium added to the connector or add medium (e.g. 40  $\mu$ l of medium) to the opposite connector that is attached to the same media channel.